



Booth 14B19, Hall 14

Contact

Bettina König
Marketing Communications
Coperion GmbH
Theodorstrasse 10
70469 Stuttgart, Germany

Phone +49 (0)711 897 22 15
Fax +49 (0)711 897 39 74
bettina.koenig@coperion.com
www.coperion.com

Press Release

Efficient and innovative raw material handling solution

Italian Compounder Upgrades Pilot Plant with Support from Coperion

Stuttgart, September 2019 — Italy-based family-owned compounder LATI Industria Termoplastici S.p.A. has tasked Coperion with the pre-engineering and engineering of a state-of-the-art material handling line of a pilot plant at their production site at Torba (VARESE), Italy. The focus of this project is on the development of a tailor-made solution for the semi-automated and automated material handling from raw materials receiving to the extruder. A key challenge is the broad variety of different raw materials with variable properties, which requires a high flexibility of the plant design. Quick changeover times are required to increase the overall efficiency of the pilot plant. Moreover, processes like washing, cleaning and the fast removal of the equipment to facilitate short changeover times are to be considered and streamlined from a technical point of view; quick clean solutions are needed to improve and shorten the processes. This pilot plant is a key step for LATI's factory of the future, including automation and digitalization of the entire production process.

Together with the LATI experts, Coperion developed an overall material handling concept including innovations like the new versatile multi-tasking Big Bag Empty Station BES-6 for free flowing and sticking materials with an easy-cleaning concept, modular design for flexible configuration, and a flexible interface. In addition, the scope of the project includes bulk bag unloading and weighing stations as well as vacuum conveying lines managed by a unique aspirator with air rate devices and automated raw material bins handling with weighing systems. The material handling equipment is designed to easily interface with the existing Coperion K-Tron feeders of the pilot plant. The data exchange for raw material consumption and

September 2019

management in real time meets Industry 4.0 standards as well as the process optimization measures. Safety standards and ergonomics are of utmost importance to LATI and the pilot plant will be built accordingly.

LATI is specialized in high-performance thermoplastics. . Amongst their scope of products are structural, self-lubricant and conductive compounds for any industrial sector, self-extinguishing materials for E&E and appliance as well as compounds for water and food contact. LATI's product portfolio is very broad and the variety of the raw materials used in production is extremely vast. The broad variety of the raw material is exactly the challenge that drove LATI's management towards Coperion to develop a solution for the material handling of their pilot plant. Coperion's broad experience in difficult to handle materials as well as to handle a large variety of materials at the same time supported LATI Group's management in their decision to kick-off their pilot plant together with Coperion.

Michela Conterno, CEO of LATI, sums up her take on the project: "We were looking for a strong partner with extensive expertise in the field of difficult to handle and efficiently convey materials. Coperion has been a long-term partner and with this new pilot line project they helped us tremendously to raise the bar for the complex tasks of handling such a large variety of products and additives as we have. New technical developments and an innovative technical concept convinced us to execute this pilot plant project together with Coperion."

Emanuele Falavena, Sales Manager, Coperion Italy, says: "With this project Coperion is able to prove its innovation drive. The enormous amount of materials to be handled challenged our team. In the end we came up with a flexible, efficient concept, which meets LATI's requirements regarding process optimization, safety, efficiency and flexibility".

Coperion is the international market and technology leader in compounding and extrusion systems, feeding and weighing technology, bulk materials handling systems and services. Coperion designs, develops, manufactures and maintains systems, machines and components for the plastics, chemicals, pharmaceutical, food and minerals industries. Within its four divisions – Compounding & Extrusion, Equipment & Systems, Materials Handling and Service – Coperion has 2,500 employees and nearly 30 sales and service companies worldwide. Coperion K-Tron is part of the Equipment & Systems division of Coperion. For more information visit www.coperion.com or email info@coperion.com.

September 2019

LATI Industria Termoplastici S.p.A is a family-owned leader in high technology solutions for the thermoplastic industry. Its range of products includes high-performance materials, special compounds, self-extinguishing materials, reinforced and filled products. Mixing innovation and tradition, Lati is in the forefront of creating new solutions providing thermoplastic compounds to the main industrial sectors. For more information visit www.lati.com

⌘ ⌘ ⌘

Dear colleagues,
You will find this press release in English, Italian and German together with the pictures in printable quality for download at <https://www.coperion.com/en/news-media/newsroom/>

Editor contact and copies:

Dr. Jörg Wolters, KONSENS Public Relations GmbH & Co. KG,
Hans-Kudlich-Strasse 25, D-64823 Gross-Umstadt
Tel.: +49 (0)60 78/93 63-0, Fax: +49 (0)60 78/93 63-20
mail@konsens.de, www.konsens.de

September 2019

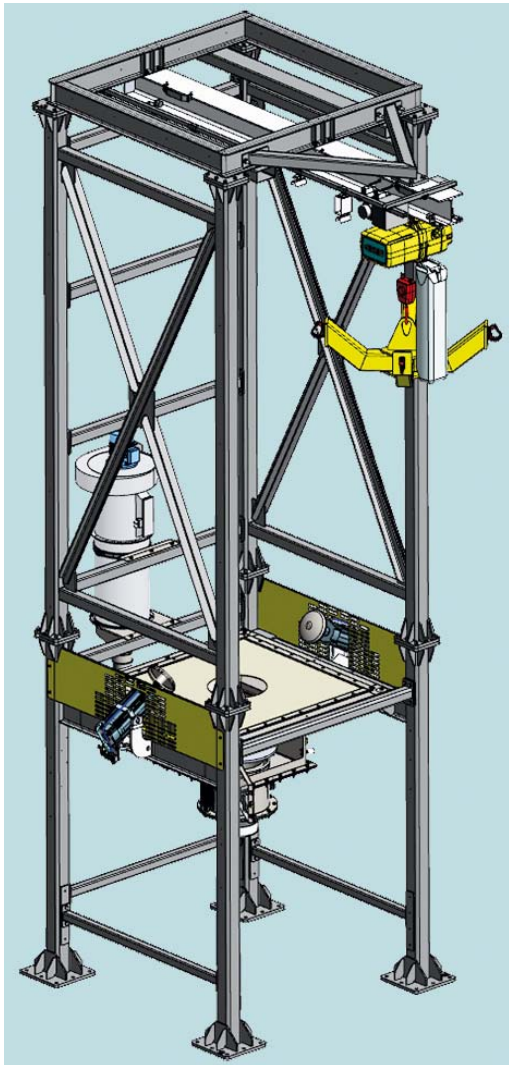

Coperion's new big bag empty station BES6 for free flowing and sticking materials with an easy-cleaning concept, modular design for flexible configuration, and a flexible interface will be part of the setup of the pilot plant.

Photo: Coperion, Stuttgart

September 2019



The pilot plant's project team: Mr. Andrea Lugli (Operations Director, LATI), Mr. Emanuele Falavena (Coperion), Ms. Michela Conterno (CEO of LATI), Mr. Lorenzo Lambertini (Engineering, LATI) and Mr. Massimiliano Baroffio (Electrical Maintenance, LATI)

Photo: Coperion, Stuttgart